

Mesh grid power quality enhancement with synchronous distributed generation: optimal allocation planning using breeder genetic algorithm

Abstract. This paper discusses optimal allocation planning of synchronous distributed generation (SDG) on mesh grid power system, using breeder genetic algorithm (BGA) method. This optimization technique was built to allocate SDG units for obtaining the smallest power losses, while all buses voltage awakens in standard value. Furthermore, the proposed method was tested on IEEE 30 bus test system, and the optimal solution was reached for three SDG unit installation on 27.73 MW + j1.502 MVar total power, with 22.46% power losses reduction.

Streszczenie. W artykule omówiono optymalne planowanie alokacji synchronicznej generacji rozproszonej (SDG) w systemie elektroenergetycznym sieci kratowej z wykorzystaniem metody algorytmu genetycznego rozplodnika (BGA). Ta technika optymalizacji została zbudowana w celu alokacji jednostek SDG dla uzyskania najmniejszych strat mocy, podczas gdy napięcie wszystkich magistrali zawiera się w wartości standardowej. Ponadto zaproponowana metoda została przetestowana na systemie testowym magistrali IEEE 30 i osiągnięto optymalne rozwiązanie dla instalacji trzech jednostek SDG o łącznej mocy 27,73 MW + j 1,502 MVar, przy obniżeniu strat mocy o 22,46%. **(Poprawa jakości energii sieci kratowej dzięki synchronicznemu generowaniu rozproszonemu: optymalne planowanie alokacji przy użyciu algorytmu genetycznego).**

Keywords: synchronous distributed generation, breeder genetic algorithm, power losses, voltage profile.

Słowa kluczowe: synchroniczne generowanie rozproszone, algorytm genetyczny, straty mocy, profil napięciowy.

Introduction

The unaccompanied load growth with network expansion and additional generation causes a decline in distribution system quality, which is especially significant in voltage drop [1]. This problem is commonly encountered on radial type distribution network, especially if the load center is located far from the generation center, and overcoming it requires the use of closing line tie switches. The effect is a change on each branched current, further, associated with the effectivity of power received on each node [2]. Based on this condition, it is termed mesh network. In comparison with radial types, it possesses better reliability and voltage profiles without significantly thriving, especially in the event of additional loads.

Voltage reduction is strongly influenced by the adequacy of active and reactive power, supplied by electrical plant to the load. In conventional systems, voltage and reactive power are usually controlled by adding on load tap changers (OLTC), and capacitors bank [3, 4]. This model adopts a passive distribution system because of the centralized location of the generator, which serves the load around. Furthermore, a shift in paradigm from passive to active systems, encouraging the distributed generation (DG) integration.

In recent years, this development is shown to be very attractive in the energy sector worldwide [5, 6], and its presence as an electrical source with close proximity to the load center impacts significantly on the distribution network [7, 8, 9, 10, 11]. In addition to the factors, it is also important to consider types of DG unit, which are classified based on construction and technological approach [12], as well as its power injection or absorption [13]. Furthermore, the DG ought to possess the ability of injecting active power, which injecting or absorbing reactive power depends on the technology applied.

Each type contributes a different effect in power quality, in terms of voltage profile improvement and decline in network power losses. DG type 1 injects active power to the network. The solar power generation is one of the examples. The impact of DG type 1 placement to offer power losses derivation and voltage profile refinement has

been investigated by [10]. The synchronous machine is categorized as DG type 2, based on its capacity to inject both active and reactive power [13]. It is applied to mini hydro and thermal generator. This integration attributes positive impacts, among other economic benefits, bus voltage improvement, reduction in line losses, heat waste utilization, emission reduction, and fuel cost minimization [14]

To obtain maximum benefit, DG integration into a distribution network requires a number consideration factors, including the number, location, and size of unit. The artificial intelligence methods like simple genetic algorithm (SGA) has widely been used for optimum placement searching of distributed generation [15, 16, 17, 18].

Meanwhile, this technique is faced with the weakness of best chromosome survival, in order to pass the selection, mutation and cross over processes. The breeder genetic algorithm (BGA) is able to overcome this challenge through the use of probability index that maintains the best chromosomes in next generation.

This paper therefore contributes a method based on improved genetic algorithm, namely BGA, which was applied to fulfill the most suitable location and size of synchronous distributed generation (SDG) with smallest power loss values in a mesh distribution network. The answers attributed to the aim of this study requires that the method be tested on IEEE 30 bus system, using SDG.

Distributed Generation

The DG injects active and reactive power, based on the synchronous machine, represented by a simple system in Fig. 1, where one bus was connected to the centralized generator and another to load and DG.

The voltage at node ' U_2 ' was determined using:

$$(1) \quad V_Y = V_x - I_x * (R_x + jX_x)$$

where: V_Y - receiving voltage, V_x - sending voltage, I_x - line current, R_x - conductor resistance, X_x - conductor reactance.

The real and reactive branch power losses were determined using formula:

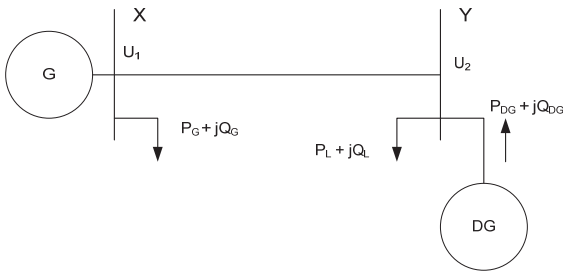

Fig.1. Equivalent diagram of the system connected to DG

$$(2) \quad P_{loss(x,y)} = \left(\frac{P_x^2 + Q_x^2}{|V_x|^2} \right) * R_x$$

$$(3) \quad Q_{loss(x,y)} = \left(\frac{P_x^2 + Q_x^2}{|V_x|^2} \right) * X_x$$

where: P_{loss} - active power losses, Q_{loss} - reactive power losses, P_x - active power, Q_x - reactive power.

Hence, the total was calculated by the addition of each branch, as specified:

$$(4) \quad P_{loss} = \sum P_{loss(x,y)}$$

The voltage drop is further calculated via equation:

$$(5) \quad \Delta V = V_x - V_y \approx \frac{R(P_L - P_G) + X(Q_L - Q_G)}{V_y}$$

where: P_L - load active power, P_G - generator active power, Q_L - load reactive power, Q_G - generator reactive power.

Based on the assumption that the DG power is constant, its integration in system, therefore, reduces voltage changes, which is due to load modification, as mathematically stated in Eq 2.

Breeder Genetic Algorithm

The genetic algorithm (GA) method is a searching technique, based on natural selection and genetic mechanism, pioneered by John Holland, and applied widely in various fields of science. This technique extensively uses practical issues, with a focus on finding optimal parameters, with the advantage of implementation ease, and the ability to quickly discover a good or acceptable solution to high dimensional problems. Furthermore, Fig. 2 illustrates the steps in the form of pseudocode.

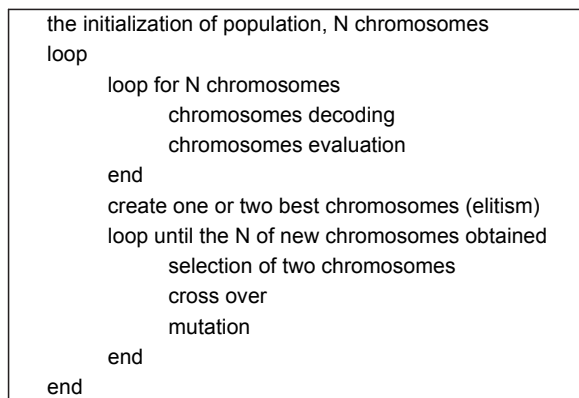

Fig.2. Pseudocode of genetic algorithm method

The unselection of chromosomes with good feasibility values in the next generation occurs as a result of the random selection process. Meanwhile, in the SGA method, these possess the possibility of not being able to follow the process in the next generation because they were not chosen. Relatively, BGA method was proposed by Muhlenbein as an improvement of the SGA [19].

The number of chromosomes that lead to the solution was well maintained by breeding probability value, and the best were preserved through random replacement on the generation, when a arbitrarily generated value is less than probability value. The scheme adopted in this practice, further, distinguishes the technique, as the SGA requires the entire N chromosomes in a generation to be replaced at once by that of the new type, from crossover and mutation results

However, this is not realistic from a biological perspective, as the real world indicates the possibility for individuals of different generations to exist at the same time, and also the fact of their constant appearance and disappearance, not on a specific generation. Furthermore, the flowchart of process optimization, using BGA is shown in Fig. 3.

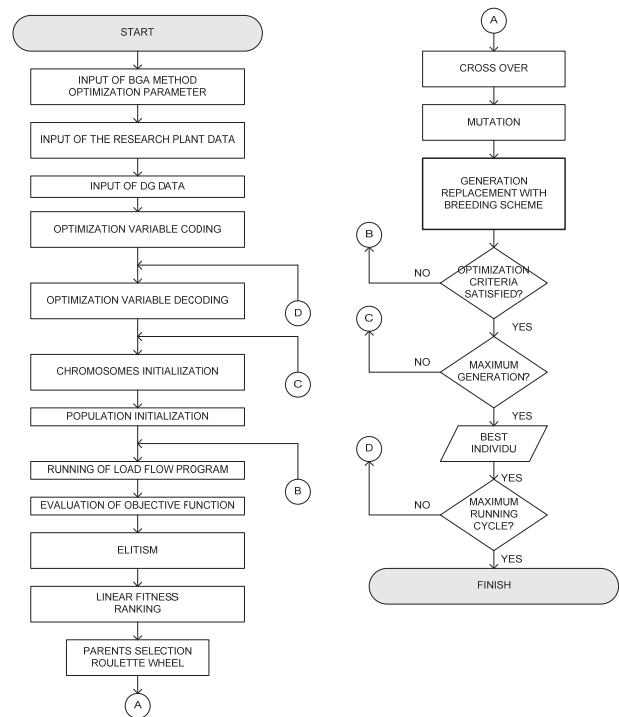

Fig.3. Optimization process using BGA method

The optimization objective function using in this research was active power losses minimization in power system. The objective function expressed as:

$$(6) \quad \text{Min } F = \sum_{i=1}^{N_L} P_{loss-i} \quad i = 1, 2, 3, \dots, N_L$$

where: F - objective function, N_L - number of line, P_{loss-i} - active losses at line - i .

This was, therefore, subjected to the constraints in equation as below:

$$(7) \quad |V_{i_{min}}| \leq |V_i| \leq |V_{i_{max}}| \quad i = 1, 2, 3, \dots, N_B$$

$$V_{i_{min}} = 0,90 \text{ pu}, V_{i_{max}} = 1,05 \text{ pu}$$

$$(8) \quad 0.1 \leq P_{DG} \leq P_{load}$$

$$(9) \quad 0.1 \leq Q_{DG} \leq Q_{load}$$

where, V_{i-min} - minimum limit of voltage, V_{i-max} - maximum limit of voltage, V_i - the voltage of bus i , N_B - total number of line, P_{DG} - real power of DG, Q_{DG} - reactive power of DG, P_{load} - total load.

In the simulation based on BGA method, maximum generation was 100, while the crossover, mutation, and breeding probability were 0.75, 0.25, and 0.2, respectively, with data of technique parameters are shown on Table 1.

Table1. Parameters of BGA method

Parameter	Value
Number of bit capacity	10
Number of bit location	5
Total of population	25
Maximum generation	100
Cross over probability	0.75
Mutation probability	0.25
Breeding probability	0.2

Simulation and Result

a. Test System

This study used a grid mesh of IEEE 30 bus test system [13], and the single line diagram of the plant under investigation is shown in Fig. 4.

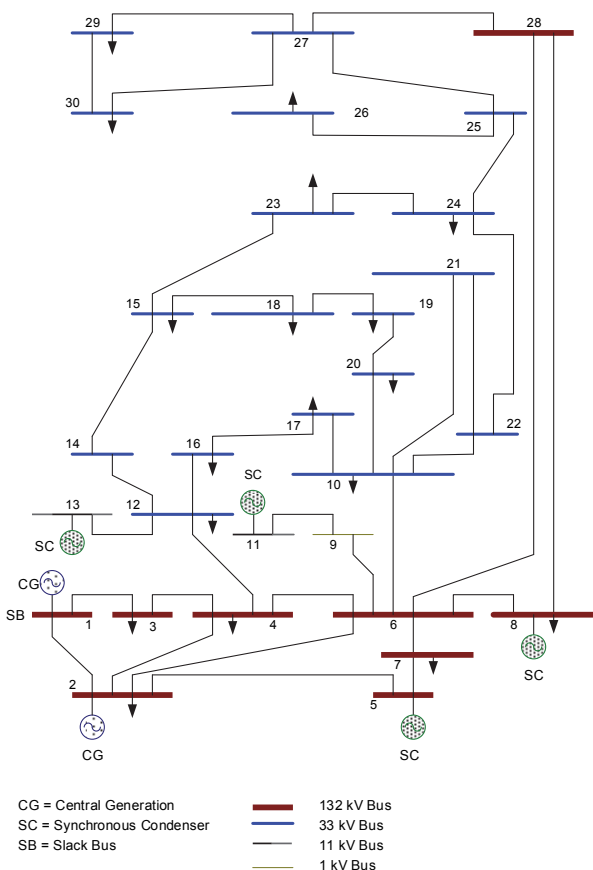

Fig.4. The IEEE 30 bus test system

This unit consisted of 5 generator and 24 load buses, where bus 1 and 2 were connected with a generator, with a

power output of 261 MW - j17.021 MVar and 40 MW + j48.8 MVar, respectively. Furthermore, the total load and active power losses of the network was of 300.998 MW + j125.144 MVar, and 17.9773 MW, respectively.

The Newton Raphson program was used to obtain a power flow analysis [20], where the penetration of three SDG units was observed to be maximal. Moreover, the proposed algorithm was built using the program, encompassing load flow study, optimal power losses calculations, as well as SDG location and size exploration.

b. Determination of size and location of SDG

The changes in power losses due to DG integration occurs at a function of the direction and magnitude of real and reactive power flow modification within a system. However, the characteristics also depends on the size and location of the DG, which subsequently has an impact on voltage deviation (positive or negative) values, in relation with the base worth.

The optimization objective function was stated as minimum power losses in this proposed method, and BGA technique was used to find the ideal size and location of SDG integration. In addition, the data applied in this simulation are shown in Table 2.

Table 2. Data of SDG

Parameter	Value
Total DG Unit	3
Minimum active power of DG	0.1 MW
Maximum active power of DG	10 MW
Minimum reactive power of DG	0.1 MVar
Maximum reactive power of DG	2.0 MVar

c. DG Impacts on the quality mesh grid

The Newton-Raphson load flow study was used to obtain bus voltage, as well as real and reactive power losses as the basic conditions of the system. The optimal size and location of SDG at certain bus was indicated by smallest power losses value on system. This was the solution based on Eq. 3 and 4. where the SDG size range was 0.1 - 10 MW and 0.1 - 2.0 MVar, and the outcome on the three load buses are shown in Table 3.

Table 3. The optimal solutions for installing of three DG units

Case	Bus	SDG Power (MW + jMVar)	Power Losses (MW)
No SDG	-	-	17.977
With SDG	19	8.870 + j0.637	13.941
	22	9.590 + j1.502	
	30	9.270 + j0.991	

The results indicate the installation of 1st SDG unit on bus 19, with 8.870 MW and 0.637 MVar as active and reactive power output, respectively. The 2nd SDG unit was installed on bus 22, with 9.590 MW and 1.502 MVar as active and reactive power output, respectively, while the 3rd, which was on bus 30, was with 9.270 MW and 0.991 MVar power output.

The real power losses reduction was about 22.45%, based on the decrease from 17.977 MW to 13.941 MW, while the reactive also showed a decline from 22.230 MVar to 7.220 MVar (15.01%), all of which are shown indepth in Fig. 5, where the active of each was generally decreased. Furthermore, the 1st line that connects bus 1 to 2, however, showed largest reduction (12.05%), after the integration of three units SDG.

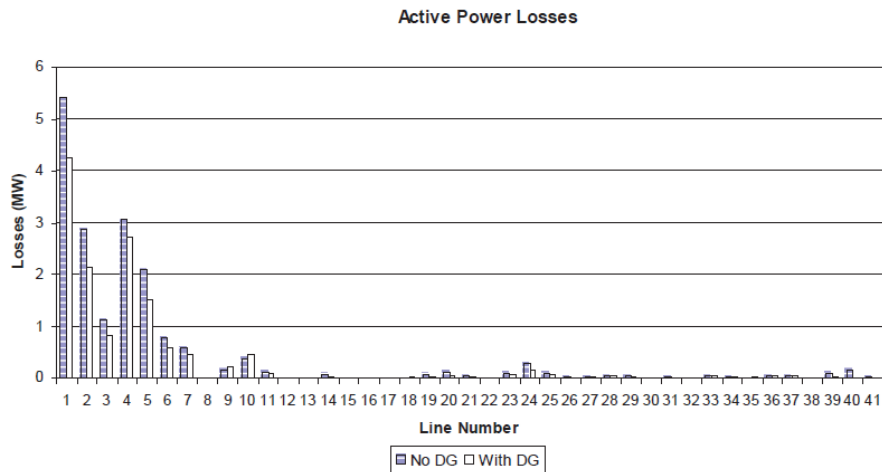

Fig.5. The line power losses of IEEE 30 bus test system

During the process of defining an optimal solution, the system bus voltage was a constraint that could not be violated. The obtained solution showed that the simultaneous placement of three SDG units had an impact on voltage improvement compared to the system condition without SDG as shown in Fig. 6.

Furthermore, this increase was noticed after SDG installation, though maintained within the standard range, as its presence delivered 27.73 MW + j1.502 MVar total power, and also improved the voltage profile by 1.48% on 300.998 MW + j125.144 MVar load.

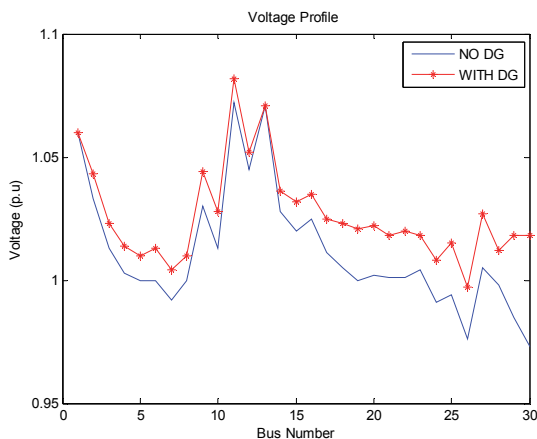

Fig.6. The voltage profile of IEEE 30 bus test system

The performance of BGA method was compared with SGA method based on a number aspects: total output power, power losses reduction, simulation processing time and convergence generation, as shown in Table 4. All simulation parameters were identical except of breeding probability variable addition for BGA method.

The comparison results showed the BGA method performance better than SGA for all of aspects. The SDG total power output with BGA was lower (27.730 MW + j3.313 MVar) than SGA (27.980 MW + j5.584 MVar). Eventhough output power value was lower, power losses reduction was higher (4.037 MW or 22.455%) versus 3.915 MW or 21.780%. For simulation processing time, the BGA method was faster (30.661 s) versus 77.609 s. The convergence had been achieved in 25th generation for BGA, while SGA in 26th generation. A comparison of convergence characteristic between the two methods is shown in Fig. 7.

Table 4. Performance comparison between BGA and SGA methods

No	Aspect	Method	
		BGA	SGA
1	SDG total power (MW + jMVar)	27.730 + j3.313	27.980 + j5.584
2	SDG location (bus number)	19; 22; 30	10; 22; 30
3	Power losses reduction (MW)	4.037	3.915
4	Power losses reduction (%)	22.455	21.780
5	Simulation processing time (s)	30.661	77.609
6	Convergence generation (i th)	25	26

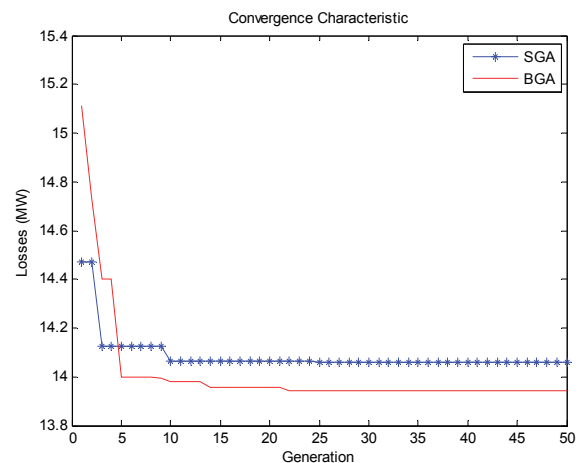

Fig.7. Comparison of convergence characteristic between BGA and SGA methods

Conclusions

This paper proposed a BGA method to determine the optimal location and power output of SDG. This method is an improvement of SGA which has weakness to maintain the best chromosome survival, in order to pass the selection, mutation and cross over processes by means of probability index utilization.

The SDG optimization process had power system active power losses minimization as an objective function. The system bus voltage was the main constraint that could not be violated during simulation process. The simulation was conducted under constant system load condition.

The optimization technique with BGA method in an attempt to successfully identify an ideal planning allocation of multiple SDGs, was able to improve IEEE 30 mesh grid power quality. In addition, SDG supplied real and reactive power, with a total of 27.73 MW + j1.502 MVar on the system, and the impact was a reduction in active power losses by about 22.45%, with the entire bus voltage remaining within standard values.

The BGA method showed better performance than SGA method for all aspects: total output power, power losses reduction, simulation processing time, and convergence generation. The BGA method indicated a higher system power loss reduction with lower power output of SDG. It also provided a faster simulation time processing and convergence.

Authors: Dr. Ir. Yusran, ST., MT., Universitas Hasanuddin, Department of Electrical Engineering, Jalan Poros Malino km 6 Bontomarannu Gowa, Indonesia, E-mail: yusranibnu@yahoo.com, yusran@unhas.ac.id; Yuli Asmi Rahman, ST., MT., Universitas Tadulako, Department of Electrical Engineering, Palu, Indonesia, E-mail: yuliasmi.rahman81@gmail.com; Dr. Indar Chaerah Gunadin, ST., MT., Universitas Hasanuddin, Department of Electrical Engineering, Jalan Poros Malino km 6 Bontomarannu Gowa, Indonesia, E-mail: indarcg@gmail.com; Dr. Ir. Sri Mawar Said, MT., Universitas Hasanuddin, Department of Electrical Engineering, Jalan Poros Malino km 6 Bontomarannu Gowa, Indonesia, E-mail: srinawarsaid@yahoo.com; Prof. Dr. Eng. Syafaruddin, S.T, M.Eng., Universitas Hasanuddin, Department of Electrical Engineering, Jalan Poros Malino km 6 Bontomarannu Gowa, Indonesia, E-mail: syafaruddin.unhas@gmail.com

REFERENCES

- [1] Driesen J., Belmans R., Distributed Generation: Challenges and Possible Solutions, *Proceeding of IEEE Power Engineering Society General Meeting*, (2006), 1-8, Montreal-Que, Canada.
- [2] Pepermans G., Driesen J., Haeseldonckx D., Belmans R., D'haeseleer W., Distributed Generation: Definition, Benefits and Issues. *Energy Policy*, (2005), Vol. 33, Issue 6, 787-798
- [3] Baiek M.M., Esmαιο A.E., Nizam M., Anwar M., M.S. Atia M.S., Derivative Load Voltage and Particle Swarm Optimization to Determine Optimum Sizing and Placement of Shunt Capacitor in Improving Line Losses, *Journal Of Mechatronics, Electrical Power, and Vehicular Technology*, (2016), 67-76
- [4] Rahman Y.A., Manjang S., Yusran., Ilham A.A, Evaluating the Effect Placement Capacitor and Distributed Photovoltaic Generation for Power System Losses Minimization in the Radial Distribution System, AIP Conference Proceedings 1941, 020027 (2018)
- [5] Sikorski T., Power Quality in Low-Voltage Distribution Network with Distributed Generation, *Przeglad Elektrotechniczny*, (2015), Vol. 2015, No. 06, 32
- [6] Yusran, Electromagnetic Field Impact on 150 kV Raha-Baubau Transmission Line, *IOP Conf. Ser.: Earth Environ Sci.* 235 012107 (2019)
- [7] Rao R.S., Ravindra K., Satish K., Narasimham S., Power Loss Minimization in Distribution System Using Network Reconfiguration in the Presence of Distributed Generation, *IEEE Transactions on Power Systems*, (2013), Vol. 28, 317-325
- [8] Othman M., El-Khattam W., Hegazy Y.G., Abdelaziz A.Y., Optimal Placement and Sizing of Distributed Generators in Unbalanced Distribution Systems Using Supervised Big Bang-Big Crunch Method, *IEEE Transactions on Power Systems*, (2015), Vol. 30, 911-919
- [9] Kang Q., Zhou M., An J., Wu Q., Swarm Intelligence Approaches to Optimal Power Flow Problem with Distributed Generator Failures in Power Networks, *IEEE Transactions on Automation Science and Engineering*, (2013), Vol. 10, 343-353
- [10] Rahman Y.A., Manjang S., Yusran., Ilham A.A, Distributed generation's integration planning involving growth load models by means of genetic algorithm, *Archives of Electrical Engineering*, (2018), Vol. 67, 667-682
- [11] Kadir A.F.A., Mohamed A., Shareef H., Wanik M.Z.C., Ibrahim A.A., Optimal Sizing and Placement of Distributed Generation in Distribution System Considering Losses and THDv Using Gravitational Search Algorithm, *Przeglad Elektrotechniczny*, (2013), Vol. 2013, No. 04, 132
- [12] El-Khattam W., Salama M.M.A., Distributed Generation Technologies, Definitions and Benefits, *Electric Power Systems Research*, (2004), Vol. 71, 119-128
- [13] Yusran, Ashari M., Soeprijanto A., Optimization Scheme of Distributed Generation Installation Growth Considering Network Power Quality, *Journal of Theoretical and Applied Information (JATIT)*, (2013), Vol. 53, No.1, 30-39
- [14] Basua A.K., Chowdhuryb S.P., Paul S., Microgrids: Energy Management by Strategic Deployment of DERs - A Comprehensive Survey, *Renewable and Sustainable Energy Reviews*, (2011), Vol. 15, Issue 9, 4348-4356
- [15] Baghipour R., Hosseini S.M., Placement of DG and Capacitor for Loss Reduction, Reliability and Voltage Improvement in Distribution Networks using BPSO, *International Journal of Intelligent Systems and Applications*, (2012), Vol. 4, 57
- [16] B. Bhattacharyya B., Rani S., Vais Ram I., Bharti Indradeo P., GA Based Optimal Planning of VAR Sources Using Fast Voltage Stability Index Method, *Archives of Electrical Engineering*, (2016), Vol. 65, 789
- [17] Abou El-Ela A.A., S. Allam S.M., Shatla M.M., Maximal Optimal Benefits of Distributed Generation Using Genetic Algorithms, *Electric Power Systems Research*, (2010), Vol. 80, 869-877
- [18] Sultana S., Roy P.K., Multi-Objective Quasi-Oppositional Teaching Learning Based Optimization for Optimal Location of Distributed Generator in Radial Distribution Systems, *International Journal of Electrical Power & Energy Systems*, (2014), Vol. 63, 534-545
- [19] Mühlenbein H., Predictive Models for The Breeder Genetic Algorithm I. Continuous Parameter Optimization, *Journal Evolutionary Computation*, (1993), Vol. 1, Issue 1, 25-49
- [20] Saadat H., *Power System Analysis*, 2nd ed, (2004), McGraw-Hill, Singapore