

PAPER • OPEN ACCESS

Solar Pond Potential as A New Renewable Energy in South Sulawesi

To cite this article: Nur Fadiah Baso *et al* 2018 *J. Phys.: Conf. Ser.* **979** 012039

View the [article online](#) for updates and enhancements.



IOP | ebooks™

Bringing you innovative digital publishing with leading voices to create your essential collection of books in STEM research.

Start exploring the collection - download the first chapter of every title for free.

Solar Pond Potential as A New Renewable Energy in South Sulawesi

Nur Fadliah Baso, Indar Chaerah Gunadin, Yusran

Postgraduate Student of Electrical Engineering Department, ²Department of Electrical Engineering.

Jl. Perintis Kemerdekaan KM.10 Makassar, Sulawesi Selatan, 90245, Indonesia

E-mail : nfadliahb@gmail.com

Abstract. Renewable energy sources need to be developed to maintain the electric energy availability by utilizing oceanic energy, namely solar pond energy. This energy is highly influenced by several factors including salinity, air temperature and solar radiation. This study was focused on finding the potential of solar pond in South Sulawesi, a region with fairly high solar radiation and abundant salt water raw materials availability. The method used in this study was analyzing the values from the mathematic models of daily horizontal solar radiation, air temperature, wind speed, relative humidity and atmospheric pressure for the last 22 years which were finalized using MATLAB. The findings of this study will show the areas with good potentials to apply solar pond in South Sulawesi that can be utilized in various fields including power generator, industrial heating process, desalination and heating for biomass conversion.

1. Introduction

One of the potentials from oceanic energy that is still underdeveloped in Indonesia is the energy source from solar pond. Compared to others, the method of using solar thermal energy for power generation is more efficient [1]. Solar pond is a salt water mining able to store solar radiation and heat energy for a long time [2]. Solar ponds have been suggested to be simple and economical in terms of collecting and storing energy on a large scale [3]. Generally solar pond has an area of 2000 m² to 250.000 m² with depth of 4 m.

When the solar heat energy get into water, the water become hot and the hot water part will decrease its density due to expansion in the water making the hot water move upward to the surface and the cooler part moves to the bottom. Due the presence of contact between hot water and surface air, there is a calorie release by conduction and convection in the hot water, wasting the calorie in the water. In order for the heat in the water is not wasted, salts are added into the water. When the salted water is heated, the salt can be easily soluble in the water, so that the formerly light hot water can gain more weight because the salt solution make the water density heavier and the cooler water move upward to the surface because it is lighter. Figure 1 represents the layer modeling in solar pond.

The heat produced in LCZ which later can be used for power generation, industrial heating process, desalination and heating for biomass conversion. The utilization of LCZ heat energy is realized after the temperature on LCZ has reached 70 °C [4]. On the power generation, the growth of widely-opened transmission access has a significant side effect for modern utilities [5]. The planning development scheme to anticipate the distributed generation growth is a necessity for electrical network



operator. Thus, the planning will regulate the capacity, location and type of transmission and distributed generation [6].

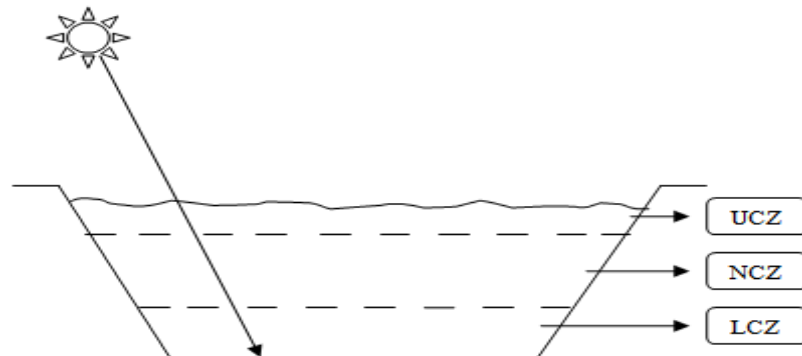

Figure 1. Solar Pond layer modeling

The solar pond layer modeling is divided into three parts:

- Upper Convective Zone (UCZ) / Upper Zone has a depth of 0.3 – 0.5 m, receives direct solar radiation, has a well-distributed low salinity and temperature along its entire depth.
- Non-Convective Zone (NCZ) / Gradient Zone has a depth of 1- 1.5 m, has varied salinity and temperature distribution as depth function. The higher the depth in NCZ the greater its salinity and temperature.
- Lower Convective Zone (LCZ) / Storage Zone has a depth of 1.5 - 2 m, has constant salinity and temperature and well-distributed along its entire depth. This area functions as thermal storage of solar pond, where the LCZ temperature can be utilized based on its need.

2. Material and Method

2.1 Study Area

The selected study areas were located in South Sulawesi, namely Jeneponto at coordinates of 5°35'17.5"S 119°33'53.9"E and Pangkep at coordinates of 4°43'50.6"S 119°31'42.8"E because these two areas are salt producer and have thermal potential to explore. Salinity is one of the important parameters to catch heat in solar pond. The higher the salinity in solar pond the greater the heat produced [7,8]. Figure 2 shows the maps of Jeneponto and Pangkep in South Sulawesi.



Figure 2. Map of Jeneponto and Pangkep, South Sulawesi

2.2 Data Source

Data were obtained from NASA website that records average data; daily solar radiation horizontal, air temperature, wind speed, relative humidity, and atmospheric pressure for the last 22 years [9,10]. The obtained data were then processed to obtain storage zone heat in solar pond.

Table 1. The Value Of Parameter In Jenepono

Month	Daily Solar Radiation Horizontal (kWh/m ² /day)	Air Temperature (° C)	Wind Speed (m/s)	Relative Humidity (%)	Atmospheric Pressure (kPa)
January	4.57	26.4	4.36	81.1	100
February	4.84	26.3	4.43	80.3	100
March	5.75	26.4	3.29	81.5	100
April	5.91	26.6	3.36	80.9	100
May	5.97	26.6	4.76	79.4	100
June	5.67	26.1	5.46	79.0	100
July	5.95	25.7	5.92	76.6	100
August	6.70	25.8	6.09	72.7	100
September	7.22	26.3	5.59	71.5	100
October	7.05	26.7	4.25	73.7	100
November	6.09	26.7	3.09	78.6	100
December	4.75	26.5	3.46	80.4	100
Annual	5.87	26.3	4.50	78.0	100

*Data Source = NASA 2017 [9]

Table 2. The Value Of Parameter In Pangkep

Month	Daily Solar Radiation Horizontal (kWh/m ² /day)	Air Temperature (° C)	Wind Speed (m/s)	Relative Humidity (%)	Atmospheric Pressure (kPa)
January	4.68	25.8	3.62	81.5	99.4
February	4.93	25.9	3.65	79.7	99.4
March	5.54	26.0	2.70	81.2	99.4
April	5.80	26.0	2.57	81.9	99.4
May	5.73	25.9	3.85	80.9	99.4
June	5.53	25.5	4.42	80.1	99.5
July	5.74	25.2	4.83	76.7	99.5
August	6.48	25.8	5.01	69.8	99.5
September	6.83	26.6	4.56	67.0	99.5
October	6.64	26.8	3.33	70.9	99.4
November	5.63	26.2	2.46	78.7	99.4
December	4.46	25.9	2.95	80.7	99.4
Annual	5.67	25.9	3.66	77.4	99.4

*Data Source = NASA 2017 [10]

2.3 Model Description

Heat losses is an important factor that affects solar pond performance. Heat losses can be convective loss, radiation loss, evaporation and side loss [4]. Figure 3 shows the heat balance in the Upper Zone.

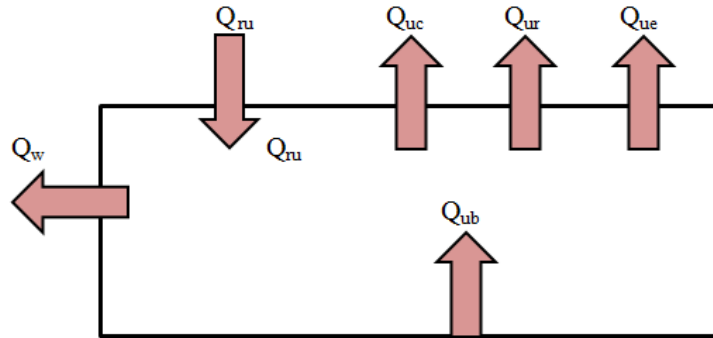

Figure 3. Heat Balance On Upper Zone

The steady state of model of Upper Zone can be written as :

$$\rho_u C_{pu} A_u X_u \frac{dT_u}{dt} = Q_{ru} + Q_{ub} - Q_{uc} - Q_{ur} - Q_{ue} - Q_w \tag{1}$$

The left hand side of Equation (1) represents the useful heat accumulated in the upper convective zone. For the right hand side of the equation, Q_w is the heat loss through walls of the pond. In this work $Q_w = 0$ (i.e. it is supposed that walls are well insulated) [4]. Equation (1) which represents energy conservation in the UCZ can therefore be rewritten as:

$$\rho_u C_{pu} A_u x_u \frac{dT_u}{dt} = A_u \left[Q_{ru} + \frac{[T_s - T_u]}{\frac{1}{h_1} + \frac{x_{NCZ}}{K_w} + \frac{1}{h_2}} - \{(5.7 + 3.8v)[T_u - T_a]\} - 4.708 \times 10^{-8} \{T_u^4 - [0.0552(T_a)^{1.5}]^4\} - [\lambda h_c (P_u - P_a)] / [(1.6c_s P_{atm})] \right] \tag{2}$$

Heat losses occurred in Storage Zone is derived from heat transfer by conduction. Appropriate isolation can be used for side edge and lower part of Storage Zone to improve the performance of Storage Zone. Gradient Zone can also influence the performance by inhibiting the ascending heat loss from Storage Zone to Upper Zone [3]. Figure 4 shows the heat balance in the Storage Zone.

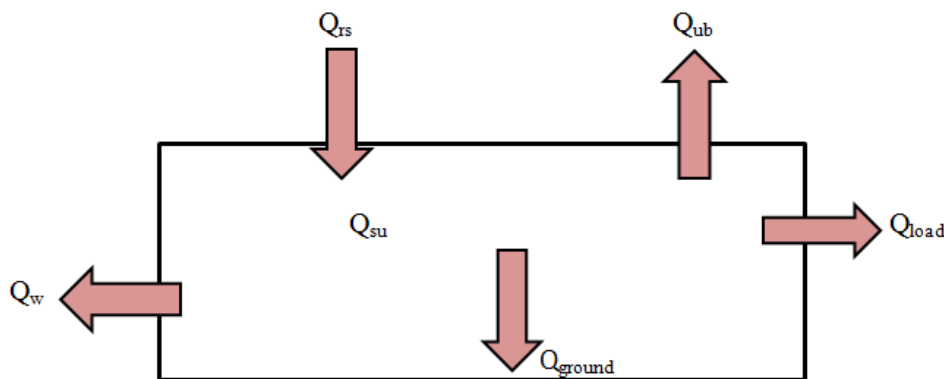

Figure 4. Heat Balance On Storage Zone

The steady state of model of Storage Zone can be written as :

$$\rho_l C_{pl} A_l X_l \frac{dT_s}{dt} = Q_{rs} - Q_{ub} - Q_{ground} - Q_{load} - Q_w \quad (3)$$

It is assumed to begin with that there is no load $Q_{load} = 0$. This corresponds to the initial warming period of the pond. In addition, it is assumed that $Q_w = 0$. Equation (3) which represents energy conservation in the LCZ can therefore be rewritten as:

$$\rho_l C_{pl} A_l x_l \frac{dT_s}{dt} = A_l \left[Q_{rs} - \frac{[T_s - T_u]}{\frac{1}{h_1} + \frac{X_{NCZ}}{K_w} + \frac{1}{h_2}} \right] - \frac{A_b [T_s - T_g]}{\frac{1}{h_3} + \frac{X_g}{K_g} + \frac{1}{h_4}} \quad (4)$$

Further details on each parameter in Equation (2) and Equation (4) are provided by Jerome, Ahmed, Wongsakorn [3] and Assad, Hazim, Alasdir [4]

3. Results and Discussion

According to NASA data, Jeneponto and Pangkep have good radiation. Radiation has a direct impact on temperatures in storage zones in solar ponds subject to gradient thickness. The deeper the gradient layer, the less radiation that enters the pool. In the gradient layer with a depth of 1 m then 36% of the incoming radiation pools are available and at a depth of 2 m will be reduced by up to 30%. Increased radiation will increase the temperature as more heat will be absorbed as mentioned before depth of the pond is an important factor in that along with the evaporation losses which can be reduced by introducing a cover on the pond [3].

The comparison of irradiation data between Jeneponto and Pangkep can be seen from Table 3 as follow:

Table 3. Irradiation data between Jeneponto and Pangkep

Month	Jeneponto Radiation (MJ/m ² /day)	Pangkep Radiation (MJ/m ² /day)
January	16.452	16.848
February	17.424	17.748
March	20.700	19.944
April	21.276	20.880
May	21.492	20.628
June	20.412	19.908
July	21.420	20.664
August	24.120	23.328
September	25.992	24.588
Oktober	25.380	23.904
November	21.924	20.268
December	17.100	16.056
Annual	21.132	20.412

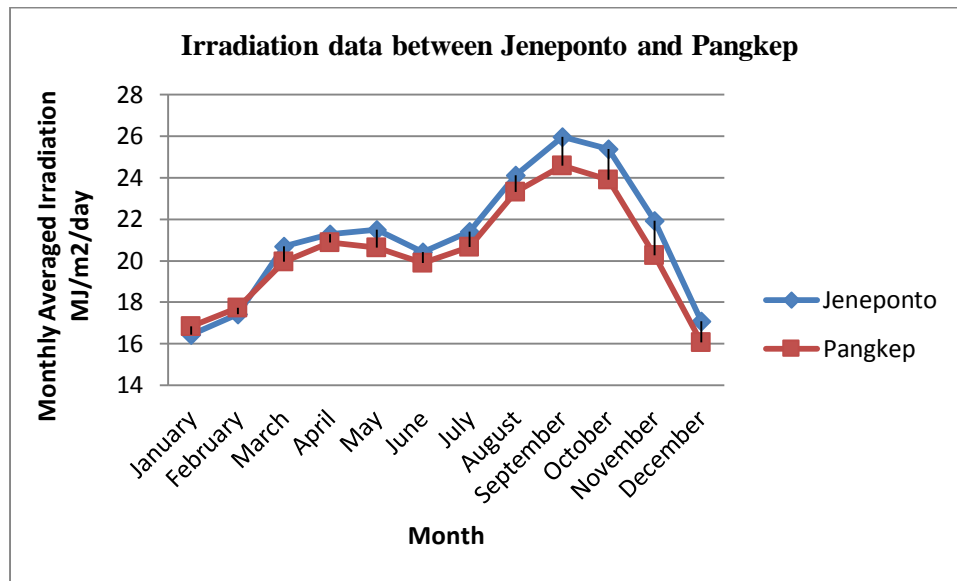

Figure 5. The Plot of Jeneponto and Pangkep Irradiation data

Figure 5 shows that Jenepono has the highest radiation value in September (25.992 MJ/m²/day) and lowest radiation value in January (16.452 MJ/m²/day). Whereas, Pangkep has the highest radiation in September (24.588 MJ/m²/day) and the lowest radiation value in December (16.056 MJ/m²/day).

Equations (2) and (4) have been solved by using MATLAB. By this method Equations (2) and (4) can be solved depending on the initial values of the unknown temperatures T_u and T_s . These initial values vary with the location of the pond and the time of year when the pond starts working. The values of the constants which are used in the model are as follows $\rho_u = 1000 \text{ kg/m}^3$, $\rho_l = 1200 \text{ kg/m}^3$, $c_{pu} = 4180 \text{ J/kg K}$, $c_{pl} = 3300 \text{ J/kg K}$, $A_u = A_l = A_b = 1 \text{ m}^2$, $h_1 = 56.58$, $h_2 = 48.279$, $h_3 = 78.12$, $h_4 = 185$ (all values in $\text{W/m}^2 \text{ K}$) and $k_w = 0.596 \text{ W/m K}$, $T_g = 23^\circ \text{ C}$. The value of x_g and k_g depends on the soil properties under the pond [4].

Figure 6 and 7 shows the temperature of storage zone for one year in Jeneponto and Pangkep areas.

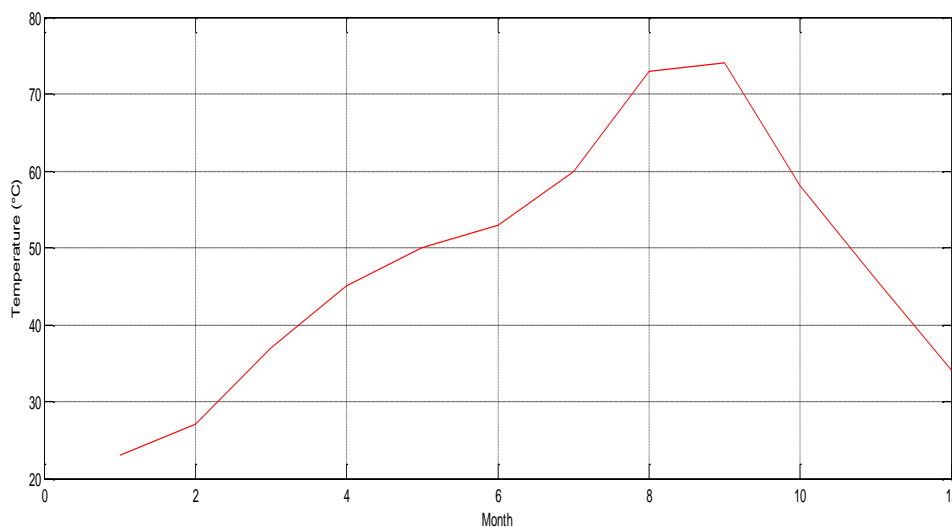

Figure 6. The Storage Zone Temperature during 12 month in Jeneponto

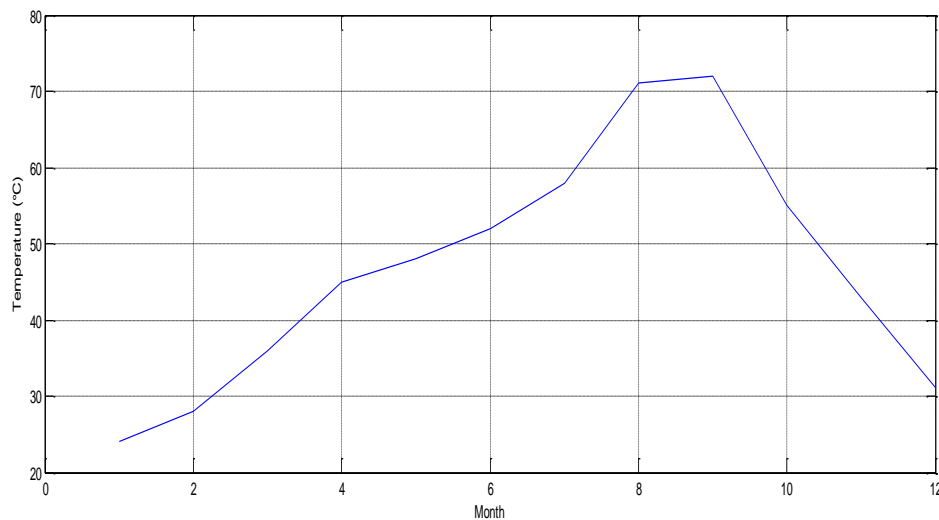

Figure 7. The Storage Zone Temperature during 12 month in Pangkep

From figure 6 and 7 it can be seen that the maximum temperatures in Storage Zone (LCZ) in Jenepono and Pangkep were observed in August to September ranging from 71°C to 74°C . Whereas, the minimum temperatures were observed in January to February, ranging from 23°C to 28°C .

With the Storage Zone (LCZ) temperature above 70°C , the solar pond has been able to be used as its intended purpose in various fields such as power generation, industrial heating process, desalination and heating for biomass conversion.

4. Conclusion

Solar Pond is a cheap and environment-friendly technology that can be applied in various fields including power generation, industrial heating process, desalination and heat for biomass conversion. This paper highlights two different locations in South Sulawesi, Jenepono and Pangkep. From the study findings it can be concluded that the two areas have potential for solar pond assignment. Jenepono has average maximum irradiance of $25.992\text{ MJ/m}^2/\text{day}$ and temperature at storage zone reached 74°C , whereas Pangkep has average irradiance of $24.588\text{ MJ/m}^2/\text{day}$ and temperature of storage zone reached 72°C .

References

- [1] Aizaz A and Yousaf R 2013 *European Scientific Journal Edition* **9** 1857-7881
- [2] Khaterin I, Bambang I W, Ridho H M, and Awan E S M 2013. *Studi Pemanfaatan Closed Cycle Salt Gradien Solar Pond (CCSGSP) Untuk Pembangkit Listrik di Pesisir Kabupaten Gresik.* (Institut Teknologi Sepuluh November)
- [3] Egbe J G, Khan A H, and Wisatesajja W 2013 *IOSR-JMCE* **6** 22-32.
- [4] Sayer A H, Al-Hussaini H, and Campbell A N. 2016. *J ScienceDirect Publisher. Solar Energy* **125** 207-218
- [5] Gunadin I C, Abdillah, Soetrijanto M A, and Penangsang, O. 2012. *Steady State stability assesment using extreme learning machine based on modal analysis* (International Review Of Electrical Engineering)
- [6] Yusran, Ashari M and Soeprijanto A 2013 *J. Theoretical and Applied Information Technology* 1992-8645
- [7] Tundee S, Srihajong N and Charmongkolpradit S 2014 *J. ScienceDirect Publisher. Energy Procedia* **48** 453-463

- [8] Dah M.M.O, Ouni M, Guizani A and Belghith A 2005 *J. ScienceDirect Publisher. Desalination* **183** 179-185
- [9] NASA Data NASA untuk Kabupaten Jeneponto <https://eosweb.larc.nasa.gov/cgi-bin/sse/grid.cgi> (accessed on 14 Agustus 2017)
- [10] NASA Data NASA untuk Kabupaten Pangkep <https://eosweb.larc.nasa.gov/cgi-bin/sse/grid.cgi> (accessed on 14 Agustus 2107)