

Power control simulation with silicon controlled rectifier (SCR)

Cite as: AIP Conference Proceedings 2543, 040024 (2022); <https://doi.org/10.1063/5.0095093>
Published Online: 16 November 2022

Yusran, Andi Muhammad Aqsha Azhar Mangkona and Debi Ahyard Rinaldi



View Online



Export Citation

Trailblazers. ^{New}

Meet the Lock-in Amplifiers that measure microwaves.

Zurich Instruments [Find out more](#)

Power Control Simulation with Silicon Controlled Rectifier (SCR)

Yusran^{1,a)}, Andi Muhammad Aqsha Azhar Mangkona^{1,b)}, and Debi Ahyard Rinaldi^{1,c)}

¹*Department of Electrical Engineering, Universitas Hasanuddin, Bontomarannu, Gowa, Indonesia*

^{a)}Corresponding author: yusran@unhas.ac.id

^{b)}aqsha03@gmail.com

^{c)}d.ahyardrinaldi@gmail.com

Abstract. The function of alternating current (AC) power control is to control voltage, current, and average power sent from source to the load either in single-phase or in three-phase. One of the power control devices is Silicon Controlled Rectifier (SCR). In this research, the main objective was to simulate a single-phase power control circuit with SCR using SPICE program. The simulation was carried out on SPICE program to determine the parameters of load in the form of current, voltage, power, and total harmonic distortion (THD) with a SCR firing angle of 90°. The simulation was also conducted to adjust the SCR firing angle according to the desired power at resistive (R) load. Then, the simulation result was compared with the theoretical calculation. The comparison showed that the two results from simulation and theoretical calculation were close to each other. The simulation result also proved that the firing angle is inversely proportional to the load power.

INTRODUCTION

Electrical energy is utilized in various sectors such as industry, residence and offices, etc. [1,2]. One type of device that is indispensable in the industry is power control. Power control can be used to control the power in the load to minimize power losses [3]. Power control can be done by limiting the voltage or current in the load. The power controller itself can be widely applied for various things such as in the use of hybrid sources to limit one source, constant voltage regulation, motor speed regulation, and so on.

One of the devices in power control is Silicon Controlled Rectifier (SCR). In recent years SCR has become more widely used [4]. The research related to SCR is increasingly being conducted [5,6,7]. SCR is two transistors and has three legs, namely, anode, cathode, and gate. Power control can be done on the SCR via the gate leg using Pulse Width Modulation (PWM). So, controlling the power on the device can be done automatically according to the desired value.

Therefore, in this study, a power control circuit configuration with SCR will be made, and then a series of simulations will be carried out to obtain the value of the load parameters such as voltage, current and power, and then validate the simulation results with a mathematical calculation of the test circuit.

LITERATURE REVIEW

Silicon Controlled Rectifier (SCR) is a component made of silicon semiconductor material and has a function as a controller or a switch. SCR is also often called a thyristor. Figure 1 shows a basic SCR circuit.

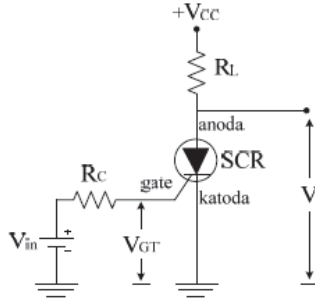

FIGURE 1. The basic SCR circuit

The input voltage (V_{in}) required to trigger an SCR is:

$$V_{in} = V_{GT} + I_{GT}R \tag{1}$$

where V_{GT} and I_{GT} are the gate trigger voltage and current. After the SCR is ON, the SCR will remain ON even though in V is reduced to zero. The only way to reset the SCR is to reduce V_{cc} to a lower value. Because the holding current (I_H) flows through the load resistance (R_L), the supply voltage (V_{cc}) for the OFF condition must be less than:

$$V_{cc} = 0.7 + I_H R_L \tag{2}$$

where I_H is the holding current that keeps the SCR ON [8].

SCR has three legs, namely the anode, cathode and gate as shown in Fig. 2. Power regulation on the load using the SCR through the gate current (I_G), that is, if the gate current (I_G) is below the holding current (I_H) then the SCR cannot drain current from anode to cathode so that current does not flow to the load. When the I_G exceeds the I_H value, the SCR will flow current to the load [9].

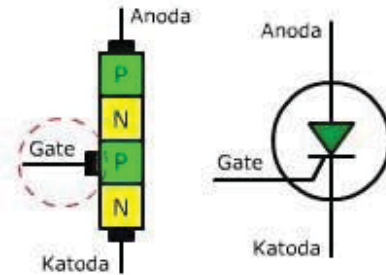

FIGURE 2. SCR legs

The single-phase voltage controller is shown in Fig. 3. The electronic switch is shown as a parallel SCR. This SCR arrangement allows the current to flow in the load in positive and negative directions. This SCR connection is called antiparallel or reverse parallel because the SCR carries current in the opposite direction [10].

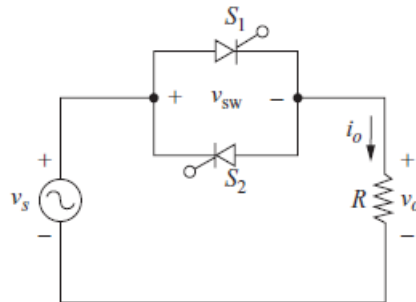

FIGURE 3. Single phase voltage controller circuit

From Fig. 3, several things can be observed, namely:

- 1) SCR cannot operate simultaneously.
- 2) The load voltage is the same as the source voltage when one of the SCRs is active. Zero load voltage when both SCRs are off.
- 3) The v_{sw} switch voltage is zero when one of the SCRs is active and is equal to the source voltage when both are inactive.
- 4) The average current at source and load is zero if the SCR is active for the same time interval. The average current in each SCR is not zero because the current of the SCR is unidirectional.
- 5) The rms current in each SCR is 1 times the rms load current if the SCR is active for the same time interval.

In Fig. 3, when SCR S1 is triggered at the gate leg, SCR S1 will operate since the trigger and will continue to be active until half a wave or when the current reaches zero [11]. When in a negative cycle, SCR S1 will block the current passing through the SCR. In contrast to SCR S2, this SCR blocks the current passing through the SCR on a positive cycle because the two SCRs are connected in reverse parallel so that SCR S2 will activate when triggered on a negative cycle [10].

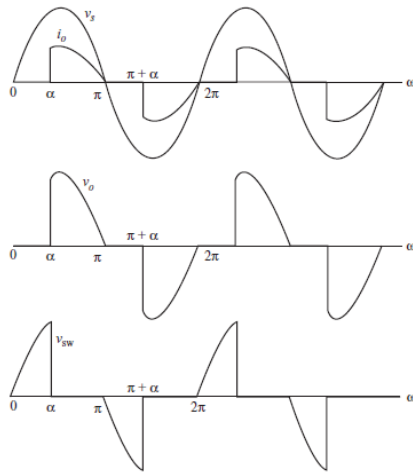

FIGURE 4. Waveform single-phase voltage control circuit (firing angle vs voltage)

Figure 4 shows the voltage waveform for a single-phase voltage controller with a resistive load. From Fig. 4, the SCR can control the voltage by controlling the voltage v_o by adjusting the firing angle on the SCR [12]. The voltage source in the circuit is

$$v_s(\omega t) = V_m \sin \omega t \quad (3)$$

The output voltage is

$$v_o(\omega t) = \begin{cases} V_m \sin \omega t & \text{for } \alpha < \omega t < \pi \text{ and } \alpha + \pi < \omega t < 2\pi \\ 0 & \text{otherwise} \end{cases} \quad (4)$$

The rms voltage is determined by calculating the positive and negative symmetries of voltage waveform. While, the rms voltage calculation can be done by calculating half a wave [10]:

$$V_{0,rms} = \sqrt{\frac{1}{\pi} \int_{\alpha}^{\pi} [V_m \sin \omega t]^2 d(\omega t)}$$

$$V_{0,rms} = \frac{V_m}{\sqrt{2}} \sqrt{1 - \frac{\alpha}{\pi} + \frac{\sin(2\alpha)}{2\pi}} \quad (5)$$

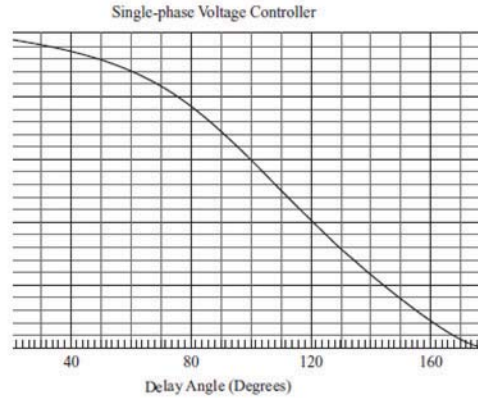

FIGURE 5. Relation of the rms stress to the load with the firing angle α

At SCR firing angle, load rms voltage has the same value as source rms voltage value. The rms voltage relationship to the load as shown in Fig. 5. The rms current in the load is

$$I_{0,rms} = \frac{V_{0,rms}}{R} \quad (6)$$

Since the source and load currents are non-sinusoidal, harmonic distortion is taken into consideration when designing and implementing ac voltage controllers. The current harmonic distortion at the load is obtained from the Fourier equation. The relationship of normalized content (C_n) and the firing angle of SCR are shown in Fig. 6. Then to get the value of harmonic distortion:

$$I_{1,rms} = C_n I_{base} \quad (7)$$

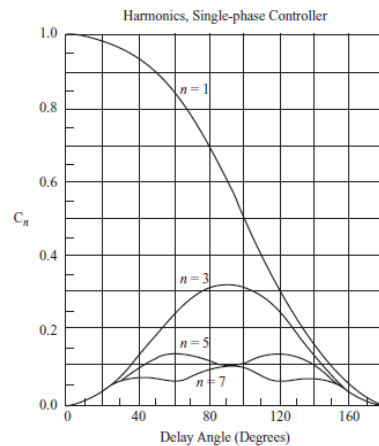

FIGURE 6. Relationship of normalized content (C_n) and firing angle of SCR

CIRCUIT CONFIGURATION

Figure 7 is a series of tests in this study. The series consists of:

1. Source voltage AC 220 V, 50 Hz
2. Two SCRs in reverse parallel circuit
3. The load of 10 Ohm resistor
4. Two oscillator generators to trigger SCR
5. Two pieces of gain to increase the oscillator voltage

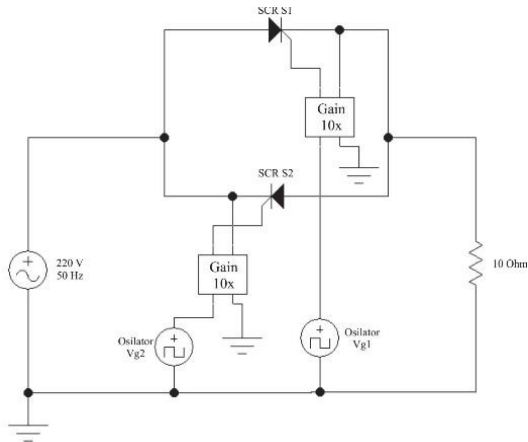

FIGURE 7. Simulation circuit

In this test, a simulation will be carried out on the SPICE application to determine the parameters of load in the form of current, voltage, power, and harmonic distortion (THD) with a firing angle of 90° on the SCR and adjust the firing angle on the SCR according to the desired power at load R.

SIMULATION RESULT

Simulation I

Figure 8 is the simulation result of a series of simulation with an SCR 90° firing angle. The source V_s has a period of 20 ms. Both SCRs are not triggered (at 0-5 ms), current and voltage at the load are 0.

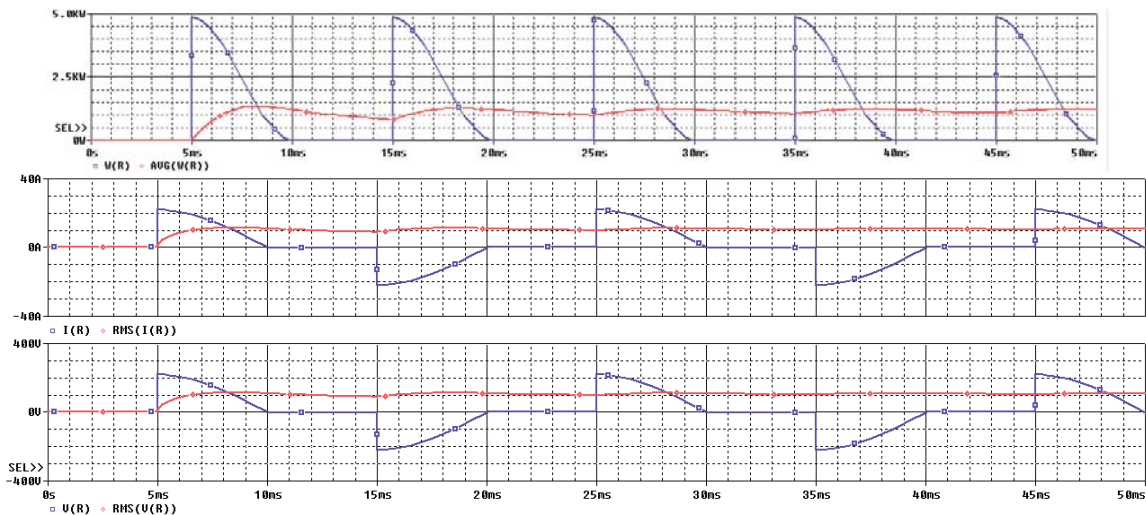

FIGURE 8. Result for simulation I

At 5 ms, the oscillator triggers SCR S1 at 90° angle which allows current to flow from anode to the cathode on SCR S1. So that, the circuit becomes closed-loop and when positive cycle approaches zero SCR S1 turns OFF and reactivates when triggered at the gate pin and on a positive cycle.

SCR S2 is connected in reverse parallel with SCR S1 so that SCR1 can work on a positive cycle and SCR S2 works on a negative cycle. In Fig. 8, it can be seen that the SCR S2 circuit is active at 15 ms (on negative cycle) or when the cycle is $90^\circ + \pi$. Like SCR S, SCR S2 ON until the cycle is close to zero and reactivates when triggered and is on negative cycle.

From the simulation results obtained:

$$\begin{aligned}V_{rms} \text{ of load} &= 109.977 V - 110.298 V \\I_{rms} \text{ of load} &= 10.998 A - 11.03 A \\W_{avg} \text{ of load} &= 1.209 kW - 1.216 kW \\THD &= 0.648\end{aligned}$$

where

V_m = Peak voltage
 $V_{0,rms}$ = Voltage rms at load
 $V_{1,rms}$ = Voltage rms at source (Volt)
 $I_{0,rms}$ = current rms at load (Ampere)
 $I_{1,rms}$ = current rms at source (Ampere)
 I_{base} = Current in the load when when the firing angle of the SCR is equal to zero
 P = Average power (Watt)
 THD = Total harmonic distortion
 α = SCR firing angle/delay angle SCR
 C_n = normalized content
 R = Load (Ohm)

From Eq. 5 it can be obtained V_{rms} at load

$$\begin{aligned}V_{0,rms} &= \frac{V_m}{\sqrt{2}} \sqrt{1 - \frac{\alpha}{\pi} + \frac{\sin(2\alpha)}{2\pi}} \\V_{0,rms} &= \frac{220}{\sqrt{2}} \sqrt{1 - \frac{90}{\pi} + \frac{\sin(2 \cdot 90)}{2\pi}} \\V_{0,rms} &= 155.563 \sqrt{1 - \frac{1.571}{\pi} + \frac{0}{2\pi}} \\V_{0,rms} &= 155.563 \sqrt{1 - 0.5} = 155.563 \sqrt{0.5} = 109.99V = 110V\end{aligned}$$

To obtain I_{rms} at load, Eq. 6 is used

$$\begin{aligned}I_{0,rms} &= \frac{V_{0,rms}}{R} \\I_{0,rms} &= \frac{110}{10} = 11A\end{aligned}$$

So that the power at the load of

$$P = I_{0,rms}^2 R = 11^2 \cdot 10 = 1210W$$

THD load is obtained by equation

$$\begin{aligned}THD &= \frac{\sqrt{I_{rms}^2 - I_{1,rms}^2}}{I_{1,rms}} \\I_{base} &= \frac{V_{s,rms}}{R} = \frac{155.563}{10} = 15.556A \\I_{1,rms} &= C_1 I_{base} \\C_1 &\approx 0.595 \\I_{1,rms} &= (0.595)(15.556) = 9.256A \\THD &= \frac{\sqrt{11^2 - 9.256^2}}{9.256} = 0.64\end{aligned}$$

From the simulation results and mathematical calculations, the precision of the simulation is close to the value of the mathematical calculation

Simulation II

Simulation II was conducted to determine the SCR firing angle associating with a 500 W specified load. To obtain the rms voltage on the load, the equation below is used

$$P = \frac{V_{0,rms}^2}{R}$$

$$V_{0,rms} = \sqrt{PR}$$

$$V_{0,rms} = \sqrt{(500)(10)} = \sqrt{5000} = 70.71V$$

To get the shooting angle, Eq. 5 is used

$$V_{0,rms} = \frac{V_m}{\sqrt{2}} \sqrt{1 - \frac{\alpha}{\pi} + \frac{\sin(2\alpha)}{2\pi}}$$

$$70.71 = \frac{220}{\sqrt{2}} \sqrt{1 - \frac{\alpha}{\pi} + \frac{\sin(2\alpha)}{2\pi}}$$

$$\frac{70.71}{155.56} = \sqrt{1 - \frac{\alpha}{\pi} + \frac{\sin(2\alpha)}{2\pi}}$$

$$0.454 = \sqrt{1 - \frac{\alpha}{\pi} + \frac{\sin(2\alpha)}{2\pi}}$$

$$0.206 = 1 - \frac{\alpha}{\pi} + \frac{\sin(2\alpha)}{2\pi}$$

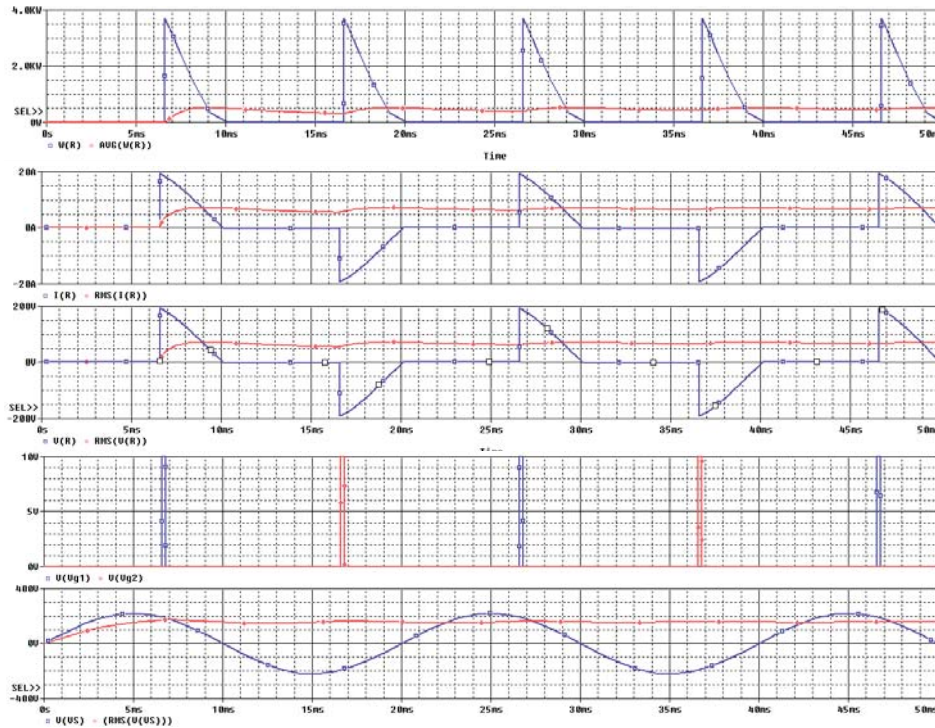

FIGURE 9. Result for simulation II

Figure 9 is a simulation result with an SCR firing angle of 118.7° . In Fig. 9, load power at 498-510 W. The results of simulations I and II have been calculated mathematically and the firing angle is inversely proportional to the power at load. The smaller SCR firing angle value makes greater load power or the load power is closer to the power source value.

CONCLUSION

Simulation of single-phase AC power control circuit with SCR shows the results in accordance with the mathematical results. The power control in the circuit is carried out by controlling the SCR firing angle. The value of SCR firing angle is inversely proportional to the load power.

REFERENCES

1. Y. Yusran, Y.A. Rahman, I.C. Gunadin, S.M. Said, and S. Syafaruddin, *Przegląd Elektrotechniczny* **1**, (2020).
2. Yusran and A. Ikhsan, in *Proc. 2nd Int. Conf. High Volt. Eng. Power Syst.* (Bali, 2019).
3. Y. Yang, P. Davari, F. Zare, and F. Blaabjerg, *IEEE Trans. Power Deliv.* **31**, 1837–1840 (2016).
4. Y.P. Patel, R.M. Tallam, B.P. Brown, D.F. Busse, J. Hu, D. Campuzano, and A.R. Strandt, *Drives IEEE Trans. Ind. Appl.* **52**, 4827–4834 (2016).
5. C.Y. Hung, T.C. Kao, J.H. Lee, J. Gong, T.Y. Huang, H.D. Su, K.C. Chang, C.F. Huang, and K.H. Lo, *Electron. Lett.* **50**, 200 (2014).
6. C.C. Yeh and N.A.O. Demerdash, *IEEE Trans. Energy Convers.* **24**, 848–859 (2009).
7. A. Damjanovic, *IEEE Trans. Ind. Appl.* **52**, 4652–4655 (2016).
8. D. Krisnandi, *J. Inform. Sist. Kendali dan Komput.* **1**, 28–34 (2007). [in Bahasa]
9. M. Khairudin, Efendi, N. Purwantiningsih, and W. Irawan, *J. Pendidikan, Teknol. dan Kejuru.* **13**, 61–72 (2016). [in Bahasa]
10. D.W. Hart, *Power Electronics* (McGraw Hill, New York, 2011).
11. K. Zhou and L. Cai, *IEEE/ASME Trans. Mechatronic* **19**, 559–569 (2014).
12. Z. V. Despotovic and Z. Stojiljkovic, *IEEE Trans. Ind. Electron.* **54**, 453–466 (2007).