

Design_Implement_IoT_Aeropo nic-(34).pdf

by

Submission date: 18-Jun-2023 09:16PM (UTC+0700)

Submission ID: 2118231366

File name: Design_Implement_IoT_Aeroponic-(34).pdf (553.75K)

Word count: 2528

Character count: 14414

Design and Implementation of IoT-Based Aeroponic Farming System

1st Riswandi
Department of Informatics, Faculty of
Engineering
Universitas Hasanuddin, Indonesia
riswandir19d@student.unhas.ac.id

4th Zainal
Faculty of Agriculture
Universitas Hasanuddin, Indonesia
zainal@unhas.ac.id

2nd Muhammad Niswar
Department of Informatics, Faculty of
Engineering
Universitas Hasanuddin, Indonesia
niswar@unhas.ac.id

8th Chong Yung Wey
National Advanced IPv6 Centre,
Universiti Sains, Malaysia
chong@usm.my

9th Zulkifli Tahir
Department of Informatics, Faculty of
Engineering
Universitas Hasanuddin, Indonesia
zulki@unhas.ac.id

Abstract— Urban farming becomes popular and enhances

food security in urban areas. Aeroponic is one of the urban farming methods where plant roots are suspended in the air and are supplied with nutrients by mist spraying. This paper describes an IoT system for monitoring and controlling evapotranspiration in an aeroponic environment. The system consists of a microcontroller, single-board computer, sensors, and actuators. The sensors in the system collect the data on plant environment parameters including air temperature, humidity, total dissolved solids (TDS), pH, and water temperature. Then, the system calculates the level of evapotranspiration using the Blaney-Criddle method to determine the appropriate actuator action to reduce the level of evapotranspiration in aeroponic using a fuzzy algorithm. The experimental result shows that our IoT system can reduce evapotranspiration, hence, it can improve the plant quality.

Keywords—Aeroponics, Microcontroller, Arduino Uno, Raspberry Pi, Sensors, Evapotranspiration, Fuzzy, Blaney-Criddle

I. INTRODUCTION

Building food security is a global challenge today. One of the sustainable development goals (SDG) of the United Nations Agenda in 2030 is to achieve Zero Hunger, which aims to achieve food security, improve nutrition and promote sustainable agriculture.

The most common urban farming method is hydroponic. Hydroponic is soilless plant cultivation systems used throughout the world to grow flowers, foliage, bedding, and vegetable crops. Plants are grown using nutrient solutions with or without a solid substrate for root growth.[1]. Certain plants with tubers at the root, such as potato plants, can optimally interfere with the aeroponic system. This method is considered the best system in hydroponic plant media systems.

The aeroponic method is considered the best system in the aeroponic growing media system, this is because placing plants with hanging roots makes plant roots get an abundant take of oxygen in the free air, by spraying nutrients directly into plant roots making plant roots more sensitive to the nutrients that are sprayed.

The growth of plant roots will be clean, and the source of nutrients obtained by the roots will also be kept clean of bacteria and fungi using an aeroponic system. Even with this

system, the content in plants cultivated on aeroponic media will be free from ingredients that can hurt the consumer's body, such as excessive levels of zinc and other ingredients that are often soluble in water in excessive amounts.

The obstacle faced in the concept of aeroponics is the high rate of evapotranspiration. Evapotranspiration is basically a combination of the process of losing water from land to the atmosphere through two processes, namely evaporation, and transpiration. Evaporation is the process where water is converted into water vapor and then the water vapor is transferred from the land surface through the evaporation process to the atmosphere, while transpiration is the evaporation of water from plants, as a result of the photosynthesis process that produces oxygen and water vapor.

Each plant has a different level of adaptation to temperature and humidity, this is due to the geographical distribution pattern of different plants with different climates, which results in differences in the level of evapotranspiration in plants. Inappropriate temperatures in certain plants result in high failure rates in crop yields.

As in the cultivation of mustard, If the temperature is below 16°C, the nutrient absorption process will be hampered, whereas if the temperature is above 30°C, the plant will be stressed quickly, The humidity level ranges from 80 to 90%. [2]. If the humidity is below 80%, the plants will quickly wither through the faster transpiration process. Meanwhile, suppose the humidity is above 90%. In that case, it causes a delayed evaporation process so that the plant roots experience a decrease in the absorption of nutrients in the water, which results in the rotting of the plant roots.

Maintaining plant root moisture is an important point in the aeroponic method to keep the root texture wet and can absorb nutrients optimally, optimal humidity or Relative Humidity (RH) in aeroponic media is very dependent on the spraying or condensation process on the plant roots. The level of humidity affects evapotranspiration, which is the suction power to lift water and nutrients from the roots to the plant stems

This study describes the design and implementation of IoT monitoring and maintains the evapotranspiration level at the normal level in aeroponic using a fuzzy algorithm

II. RELATED WORK

There are several studies about IoT implementation in agriculture Reference [3] designed and implemented an IoT system for controlling the pattern of the planting medium node so that it can perform real-time control of the chambers. Another study conducted by [4], proposed a system for controlling and monitoring the state of the growing media, including temperature, humidity, light intensity, water nutrient solution level, pH and EC values, concentration CO₂, atomization time, and atomization interval and provides automated handling based on sensor values read. Reference [5] discusses the growth of arugula plants grown using the aeroponic method with the concept of automatic irrigation in performing automatic treatments on arugula plants. Reference [6] designed and implemented an internet of things control system where control is carried out through a dashboard display interface that aims to control the temperature and humidity in the aeroponics chamber. Reference [7] developed a control and monitoring system on aeroponic growing media with an automatic system of cooling fan actuators, nutrient pumps and grow lights.

III. EVAPOTRANSPIRATION PARAMETERS

The process known as evapotranspiration (ET) is of great importance in many disciplines, including irrigation system design, irrigation scheduling, and hydrologic and drainage studies. In a broad definition, evapotranspiration is a combined process of both evaporations from soil and plant surfaces and transpiration through plant canopies. In the evapotranspiration process, the water is transferred from the soil and plant surfaces into the atmosphere in the form of water vapor[8].

This study uses the Blaney-Criddle method to determine and calculate the evapotranspiration index. This method is quite simple to calculate evapotranspiration in various types of plants based on temperature, humidity, number of daylight hours, and empirical plant coefficients. The formula for calculating evapotranspiration is as follows:

$$E_{to} = c [p (0.46T+8)] \dots \dots \dots [9]$$

Where:

E_{to} = reference evapotranspiration (mm/day)

T = average temperature during the month of observation

P = percentage of the equation of the average day/year

c = correction factor which depends on RH min or humidity

A. Temperature

Temperature is an essential thing in the use of hydroponic growing media, especially in the use of aeroponic systems. This is because the temperature can affect the acceleration of evaporation of water sources in the growing media, resulting in a decrease in nutrient levels in water sources that will become a source of plants in aeroponic growing media.

B. Humidity

Air humidity also influences the evapotranspiration process, provided that the lower the air humidity, the higher the water vapor that may experience evapotranspiration.

C. Solar Radiation

In addition, climatological aspects also play a role in this process: sun radiation. As a light source that will heat the soil,

water, and plants, the sun will evaporate the water and produce the process of evaporation in areas of standing water and transpiration in plants. The heated water will turn into water vapor and rise in the atmosphere. This is known as evaporation on the earth's surface.

There are three parameters that affect the evapotranspiration process, namely temperature, humidity, and sunlight. Temperature is an essential parameter in plant growth in aeroponic because the temperature can accelerate the evaporation in aeroponic causing the loss of nutrients dissolved in the water. Humidity affects evaporation in aeroponic where the lower the humidity, the faster the evaporation, Sunlight can heat the soil, water, and plants so that evaporation occurs.

IV. SYSTEM DESIGN AND IMPLEMENTATION

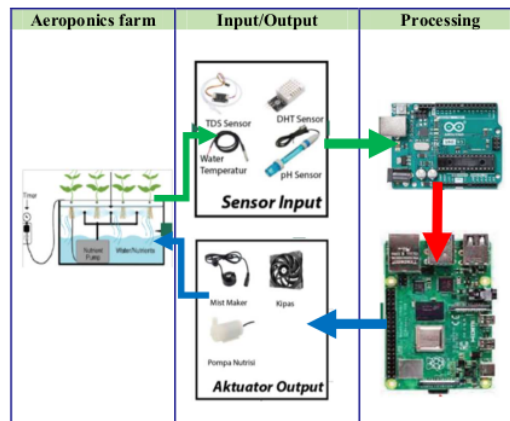

Figure 1. Hardware System.

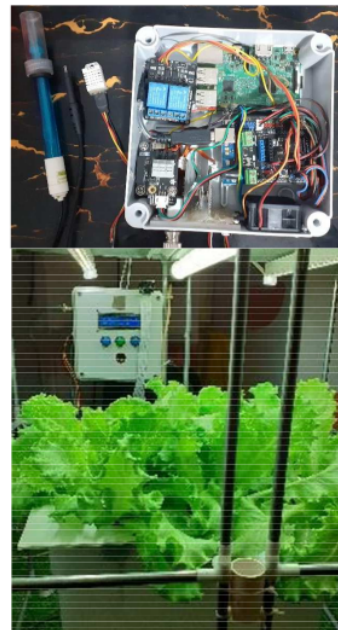

Figure 2. Implementation of Design and System.

Table 1. Hardware Specification

Components	Specification
Mini Computer	Raspberry Pi 3+/RAM 2GB
Microcontroller	Arduino UNO ATmega328P
Sensors	pH, DHT22, TDS, DS18B20
Actuators	Mist Maker, Fan, Pump
Voltage	Input Voltage 5-7V

The system consists of sensors, Arduino, raspberry pi, and actuators as shown in Fig 1. There are 4 sensors used, namely TDS, DHT, Temperature, and pH sensors. All these sensors are mounted on aquaponic and connected to Arduino.

Arduino runs the Blaney-Criddle method to determine the rate of evapotranspiration. Raspberry pi is used to drive actuators such as fans, mist makers, and pumps based on the evaporation rate received from the Arduino.

The following is the pseudocode of Blaney-Criddle implemented in the Arduino:

Pseudocode of Blaney-Criddle:

1. float C=hum value, T= Temperature value;
2. int p=24 - sunlight lighting;
3. float tempX=0.46 * T;
4. float et= tempX +8;
5. float et1=p * et;
6. float Et0= c * et1;

We use fuzzy logic to control the actuator. The fuzzy system uses the concept of multi-variables collected in a set called fuzzy, which has real number intervals[10]. The evapotranspiration value is used as a benchmark as the middle value, which indicates the standard level of evapotranspiration and becomes a reference in determining the membership function parameter for potential evaporation (Et) in the fuzzy algorithm with the following pattern:

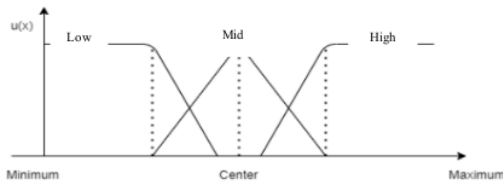

Figure 3. Membership Functions Evapotranspiration.

The following is the pseudocode of fuzzy implemented in the Raspberry Pi :

Pseudocode of Fuzzy:

1. float centerpoint, min Value, max Value;
2. string status={"low", "normal", "high"}
3. if (ET < centerpoint) Than status "high"
4. else if (Et == centerpoint And < max Value)
5. Than status "normal"
6. else (ET > centerpoint And (Et <= max Value Or Et > max Value))
7. Than status "high"

The program flow that is implemented on aeroponic smart system devices:

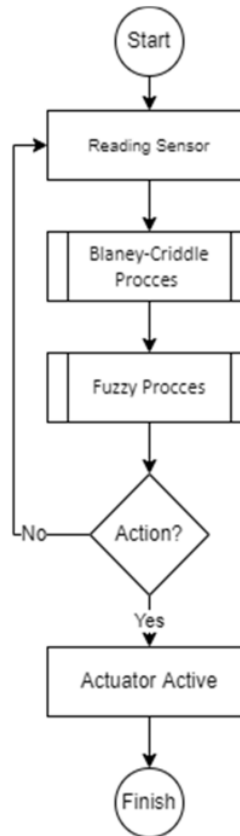

Figure 4. Flow Chart System.

V. RESULT

We compared the rate of evapotranspiration between the smart aeroponic that we designed with the conventional aeroponic. This study uses the average accumulated data of the sensor values every hour during the observation time.

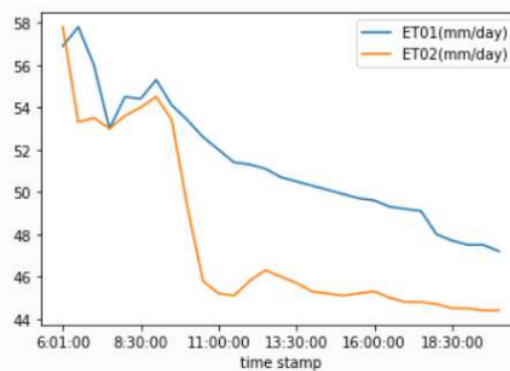

Figure 5. The Difference in Evapotranspiration Rate.

Figure 5 shows the comparison of aeroponic without IoT using a system or (ET01) and with an IoT system (ET02). We can see that evapotranspiration of ET01 and ET02 are 51.38 mm/day and 47.77 mm/day, respectively. The implemented fuzzy algorithm can significantly reduce the level of evapotranspiration in the aeroponic as shown in Fig 5.

Figure 6 shows the way the system maintains humidity using



Figure 6. The root section Using System Fogger.

A smart aeroponic system that uses a fogger system on the roots to maintain the moisture of the root. As a result, plant roots in the smart aeroponic system are more elongated and cleaner when compared to the conventional aeroponic as shown in Fig 7. with the figure as follows:



Figure 7. Different Plant Roots.

Figure 7 shows the visible differences in the growth of two plants grown using a smart aeroponics system and without plants grown without using hydroponics in general. clearly visible differences in the roots of plants, aeroponic media using condensation techniques more stimulate the growth of plant roots. Plant roots also look cleaner, this is because the roots in the aeroponic media are not exposed to water directly, thereby reducing the growth rate of moss on the plant roots

VI. DISCUSSION

This study discusses general aspects of aeroponic evapotranspiration growing media and provides an overview of systems with automation concepts using fuzzy algorithms. The next research will focus on discussing the application of several algorithms in providing aeroponic media handling and designing systems that are integrated with the forecasting concept by monitoring the level of influence of evapotranspiration on aeroponic media.

With the method of forecasting the level of evapotranspiration on aeroponic media, it is expected to be able to maintain the level of evapotranspiration by providing proper handling for aeroponic media. so that the formation of

a smart aeroponic farming method will improve the quality of plants.

VII. CONCLUSION

This study designs and implements an IoT-based aeroponic farming system. The system consists of sensors, Arduino, Raspberry pi, and actuators. The system uses 4 (four) sensors, namely TDS, DHT, Temperature, and pH sensors. All these sensors are mounted on aquaponic and connected to Arduino. Arduino runs the Blaney-Criddle method to determine the rate of evapotranspiration.

Raspberry pi is used to drive actuators such as fans, mist makers, and pumps based on the evaporation rate received from the Arduino. The experiment result shows that evapotranspiration of aeroponic without an IoT system and with an IoT system is 51.38 mm/day and 47.77 mm/day, respectively. The implemented fuzzy algorithm can significantly reduce the level of evapotranspiration

This study used the Blaney-Criddle method to calculate the evapotranspiration value on aeroponic growing media, and the average yield obtained from the evapotranspiration value was 47.77 mm/day. This value is lower when compared to aeroponic growing media without using a system with an evapotranspiration rate of 51.35 mm/day

Therefore, it can be concluded that an IoT-based aeroponic system using fuzzy logic can reduce the level of evapotranspiration and provide a significant increase in root moisture.

REFERENCES

- [1] SONG, Weitang, et al. Tomato Fusarium wilt and its chemical control strategies in a hydroponic system. *Crop protection*, 2004, 23.3: 243-247.
- [2] SUTANTO, Teguh. *Rahasia Sukses Budidaya Tanaman dengan Metode Hidroponik*. Bibit Publisher, 2015. K. Elissa, "Title of paper if known," unpublished.
- [3] BELISTA, Francis Carl L., et al. A smart aeroponic tailored for IoT vertical agriculture using network connected modular environmental chambers. In: 2018 IEEE 10th International Conference on Humanoid, Nanotechnology, Information Technology, Communication, and Control, Environment and Management (HNICEM). IEEE, 2018. p. 1-4.
- [4] LAKHIAR, Imran Ali, et al. Monitoring and control systems in agriculture using intelligent sensor techniques: A review of the aeroponic system. *Journal of Sensors*, 2018, 2018.
- [5] SALAZAR, Jhon D. Rios; CANDELO-BECERRA, John E.; VELASCO, Fredy E. Hoyos. Growing arugula plants using aeroponic culture with an automated irrigation system. *International Journal of Agricultural and Biological Engineering*, 2020, 13.3: 52-56.
- [6] JAMHARI, Charisma Aulia, et al. Design and Implementation of IoT System for Aeroponic Chamber Temperature Monitoring. In: 2020 Third International Conference on Vocational Education and Electrical Engineering (ICVEE). IEEE, 2020. p. 1-4.
- [7] RAHMAD, Iwan Fitrianto, et al. Automatic Monitoring, and Control System in Aeroponic Plant Agriculture. In: 2020 8th International Conference on Cyber and IT Service Management (CITSM). IEEE, 2020. p. 1-5.
- [8] IRMAK, Suat; HAMAN, Dorota Z. Evapotranspiration: potential or reference. *IFAS Extension, ABE*, 2003, 343: 1-3.
- [9] BLANEY, Harry French; CRIDDLE, Wayne D. *Determining consumptive use and irrigation water requirements*. US Department of Agriculture, 1962.
- [10] KLIR, George; YUAN, Bo. *Fuzzy sets and fuzzy logic*. New Jersey: Prentice-Hall, 1995

Design_Implement_IoT_Aeroponic-(34).pdf

ORIGINALITY REPORT

11%

SIMILARITY INDEX

7%

INTERNET SOURCES

6%

PUBLICATIONS

8%

STUDENT PAPERS

PRIMARY SOURCES

1	repository.tudelft.nl Internet Source	3%
2	cps-vo.org Internet Source	2%
3	Submitted to UC, Boulder Student Paper	1%
4	Novi Nurlaela, Muhammad Niswar, Ingrid Nurtanio, Yushinta Fujaya, Shigeru Kashihara, Doudou Fall. "Detection of Megalopa Phase Crab Larvae Using Digital Image Processing", 2019 International Seminar on Research of Information Technology and Intelligent Systems (ISRITI), 2019 Publication	1%
5	www.researchgate.net Internet Source	1%
6	Submitted to Universiti Putra Malaysia Student Paper	1%
7	Weitang Song, Ligang Zhou, Chengzong Yang, Xiaodong Cao, Liqun Zhang, Xili Liu. "Tomato	1%

Fusarium wilt and its chemical control strategies in a hydroponic system", Crop Protection, 2004

Publication

8

Haider Dhia Zubaydi, Mohammed Anbar, Chong Yung Wey. "Review on Detection Techniques against DDoS Attacks on a Software-Defined Networking Controller", 2017 Palestinian International Conference on Information and Communication Technology (PICICT), 2017

Publication

1 %

9

Zulkifli Tahir, Amil Ahmad Ilham, Muhammad Niswar, Dewiani Djameluddin. "The Perspectives of Design Thinking Method on Computer Network Design and Implementation", 2019 Fourth International Conference on Informatics and Computing (ICIC), 2019

Publication

1 %

10

ijcsm.springeropen.com

Internet Source

<1 %

Exclude quotes On

Exclude matches < 5 words

Exclude bibliography On